



S.CS MEGA

S.CS PAPER

S.CS COIL

**Curtainsider semitrailer S.CS MEGA
with VARIOS® TopTechnology**

Configurator

just more.

Trailer

Services

Technology



Your MEGA Trailer – configured individually

Using this brochure, you are able to choose the Curtainsider semitrailer that fulfils your requirements and expectations – from the body to the chassis and running gear up to any accessories. Our modular system makes this possible.

Overleaf you will find a table with all basic components of a Curtainsider semitrailer as well as optional special equipment. This can be filled out together with our field service staff. You only have to mark with a cross the additional elements that the trailer should be fitted with for your special purposes. Your details are the basis for making a proposal.

For optimum orientation, we will present you each equipment version using several illustrations and descriptions on the inside of the brochure. This enables you to have a better impression of the variety of components.

Another tip: Leave the table folded out when browsing through. This provides you with a better overview of the equipment, including all options at a glance and makes the desired compilation of your trailer easier.

The Schmitz Cargobull modular system for more flexibility and investment security – **just more.**

Also use our range of services for optimising your transport tasks.

● Basic fittings ○ Optional special fittings (please tick)

1. Adjustable internal height	●
2. Height-adjustable tailgate	●
3. Bulkhead made from aluminium	●
4-5. BS fittings with 620mm dropsides	○
6. High rear door	●
7. Galvanised steel corner supports	●
8. Cargo shift protection certificate	○
9. Tarpaulin with theft prevention	○
10. Flexible cargo shift protection	○
11. Pallet-wide sliding tarpaulin	●
12. Velcro fastener in the tarpaulin	○
13. Hydraulic lifting roof (manual/pneumatic operation)	●

1. Chassis Coil	○
2. Chassis Paper	○
3. Through load-securing holes in the outer frame	○
4. Wear plate at the floor end	○
5. Extra stanchions in the floor	○ central ○ outer
6. Perforated rails in the floor	○
7. Coil combi-supports	○
8. Bolted handles, can be retrofitted	○
9. Hot galvanised chassis	●
10. Floor load-bearing capacity	● 7.1 t
11. Ferry equipment	○

1. Axle lift	○
2. Aluminium rims	○
3. ROTOS® disc brakes	●
4. MRH pneumatic suspension	●
5-6. EBS with RSP stability program (Roll Stability Program)	●
7. Tyre pressure control system	○
8-9. TIS Trailer Information System	○
10. Running gear operating unit with AUTO-RESET function (automatic running height adjustment)	●

1. Side tarpaulin release device fitted at the front	○
2. Fire extinguisher	○
3. Document tube	○
4. Holder for support slats	○
5. Screw-out corner stanchions	○
6. Water tank	○
7. Pallet box	○
8. Hub-odometer	○
9. Plastic tool box	○

BODY

CHASSIS

RUNNING GEAR

ACCESSORIES / OPTIONS

SCS MEGA

SCS PAPER

SCS COIL



VARIOS

TopTechnology
Height adjustable construction
for the S.CS MEGA with
VARIOS® TopTechnology

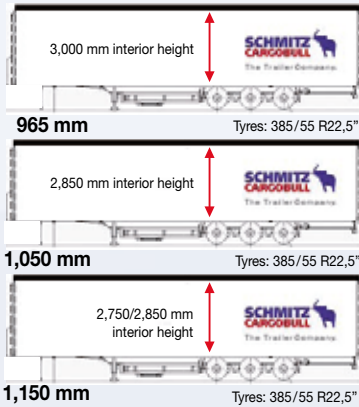

Optional: Hydraulic roof lift – each side can be individually raised



Ram protection made of steel plate protects the aluminium bulkhead from being damaged by coarse loads – proved safety in accordance with EN 12642 XL

Robust, water-proof glued floor from 28 mm thick plywood floor – a safe underground for all loads



Optional: external frame with tarpaulin hook-in edge and securing holes for position-true cargo shift protection



Galvanised pallet box for space-saving transport of up to 24 euro-pallets

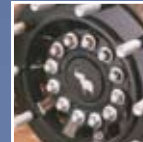

ROTOS® running gear – improved cooling of the brake system thanks to an innovative ventilation system. Minimized accident risk thanks to the RSP fitted as standard feature

S.CS MEGA – The name of the giant.

- Room for three pallet cages one on top of each other, thanks to true 3 m internal height
- Height adjustable construction for adapting to different coupling heights (965 to 1,150 mm)
- With roof lift – hydraulically raised and lowered, can also be loaded using a crane
- Pneumatic suspension with long stroke for all normal ramp heights up to 1,300 mm
- Versatile fitting details: optimally adapted to the requirements of automotive logistics

Flexible, special, individual.

- Schmitz Cargobull sliding tarpaulin Safety Roof with pre-tensioned roof edge, TÜV certified
- Either with aluminium dropsides used as a loading bay limit and sliding tarpaulin for easy handling
- Compressed air operating unit complete with lifting and lowering valve, release knob for brakes and spring suspension, axle lift as well as test connections for brake cylinder and air suspension bellows pressure, optionally with tyre pressure control and brake pad wear indicator.

Schmitz Cargobull sliding tarpaulin Safety Roof for three metre internal height over the whole pallet width right up to the roof



Optional: Cargobull Telematics (hidden installation) for a transparent logistics chain – Europe-wide detection of the trailer location, obtainable via PC or mobile phone



Locking mesh for variable positioning of the cargo shift protection beams in both front and rear



Optional: high transporting safety due to side tarpaulins with theft prevention



Smooth aluminium door, flush with four inlaid turning rod locks and mono-linkage hinge for quick loading and unloading



Safe climbing access due to the pull-out ladder



Optional: electronic ramp approach aid with acoustic and optical signal for accurate docking



Hot galvanised, bolted chassis with 10 year rust guarantee for optimum corrosion protection and fast, uncomplicated repairs



Clearly laid out control panel for operation of all pneumatic functions



Underride guard, bolted – flexibly adjustable, separated from the lamp holder. Fulfils high strength requirements



Your curtain call – the curtainsider trailer with VARIOS® TopTechnology.

S.CS MEGA with VARIOS® TopTechnology

- Ideal for volume transport thanks to the real 3m internal height together with 22.5" rims and tyres, e.g. 385/55 R22,5", serially with variable body height

S.CS COIL with VARIOS® TopTechnology

- Secure holding of steel coils, thanks to special, completely galvanised well – (up to 30t of lumped load)
- Automotive

S.CS PAPER with VARIOS® TopTechnology

- Secure loading through locking mesh for safety wedges in "every" position and continuous steel rails for Joloda rollers.
- Automotive



1



2



3

- 1. Adjustable internal height 2.75 to 3.05 m – 6 different connector options
- 2. Can be locked in 3 different heights, the tailgate adapts itself to the 2.90 to 3.05m

VARIOS
TopTechnology

Bulkhead made of aluminium with steel corner supports

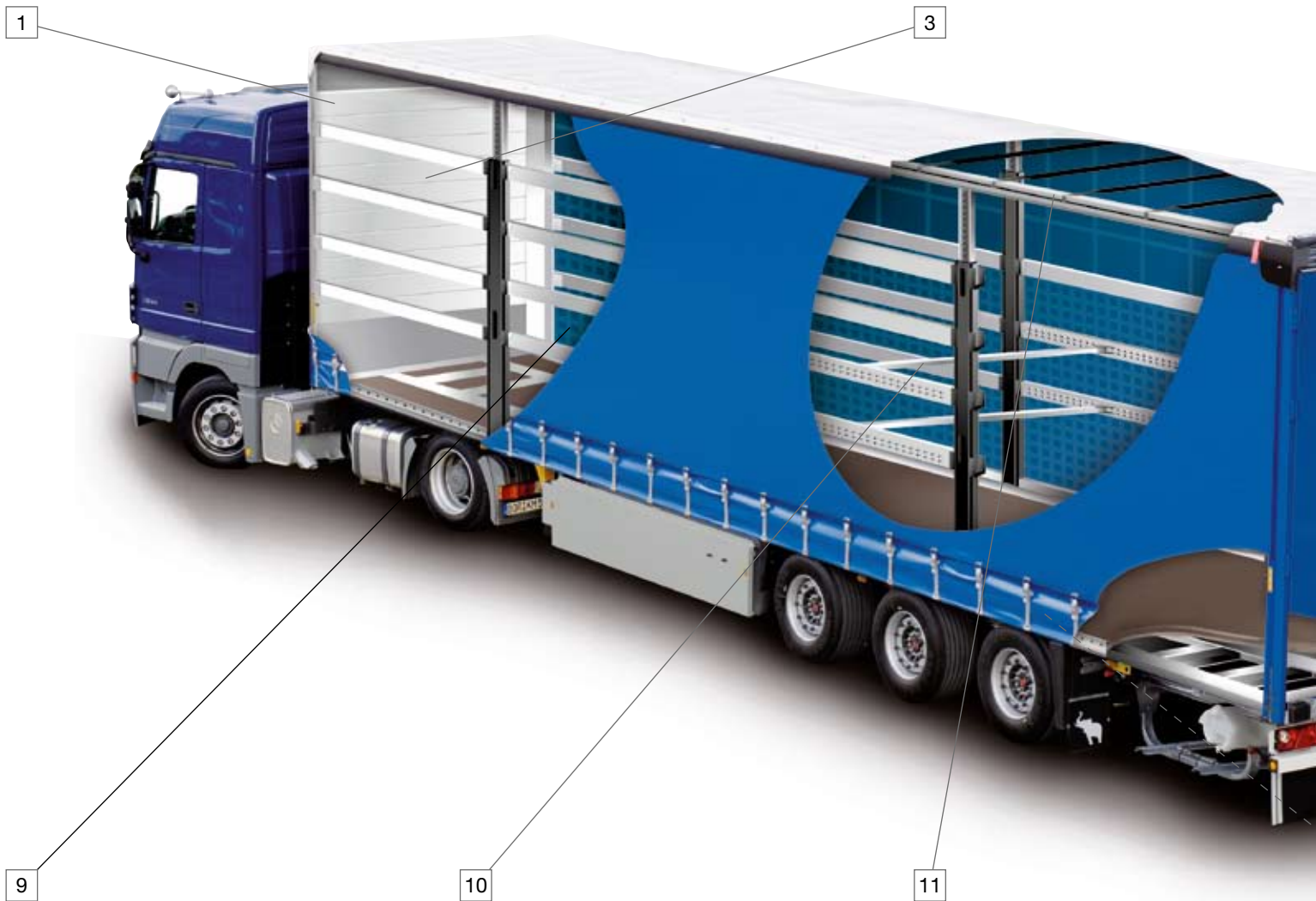

9

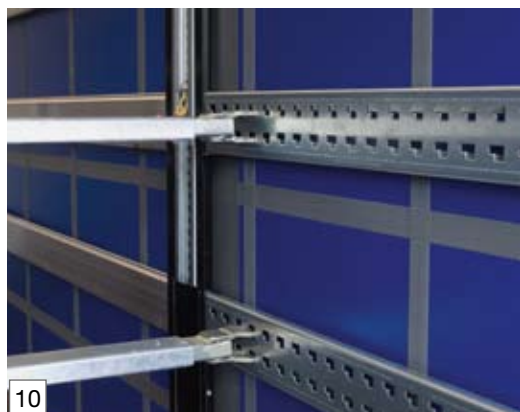

10

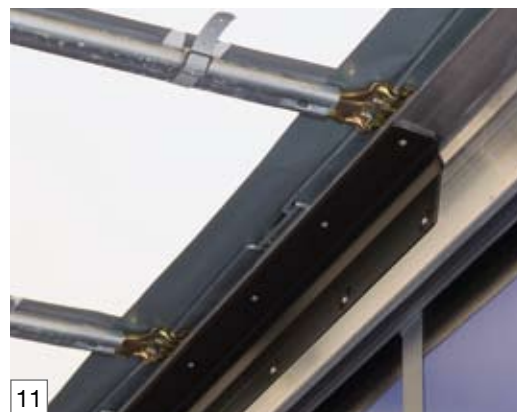

11

Tarpaulin with theft protection against intentional cutting

Flexible retaining beams ensure that the load remains safe when only partially loaded

Reinforced sliding tarpaulin with an internal width of 2,480 mm, certified according to EN 12642 XL



4
BS fittings with long tarpaulin



5
BS fittings with dropsides and sliding tarpaulin



6
High rear door with height adjustment (3 x 50 mm)



7
Galvanised steel corner supports for increased body strength



8
Cargo shift protection fittings, approved to EN 12642 XL with certificate



12
Velcro fastener in the tarpaulin for adapting to the different body heights



13
Hydro-pneumatic pump for comfortably raising the roof to the left, right or on both sides

BODY

CHASSIS

RUNNING GEAR

ACCESSORIES / OPTIONS



1

A special completely galvanised well and steel stanchions provide a secure holding for steel coils. With the well covering, the well can be closed when being used for transporting normal products



2

Continuous steel rails for the Joloda rollers with locking mesh for safety wedges

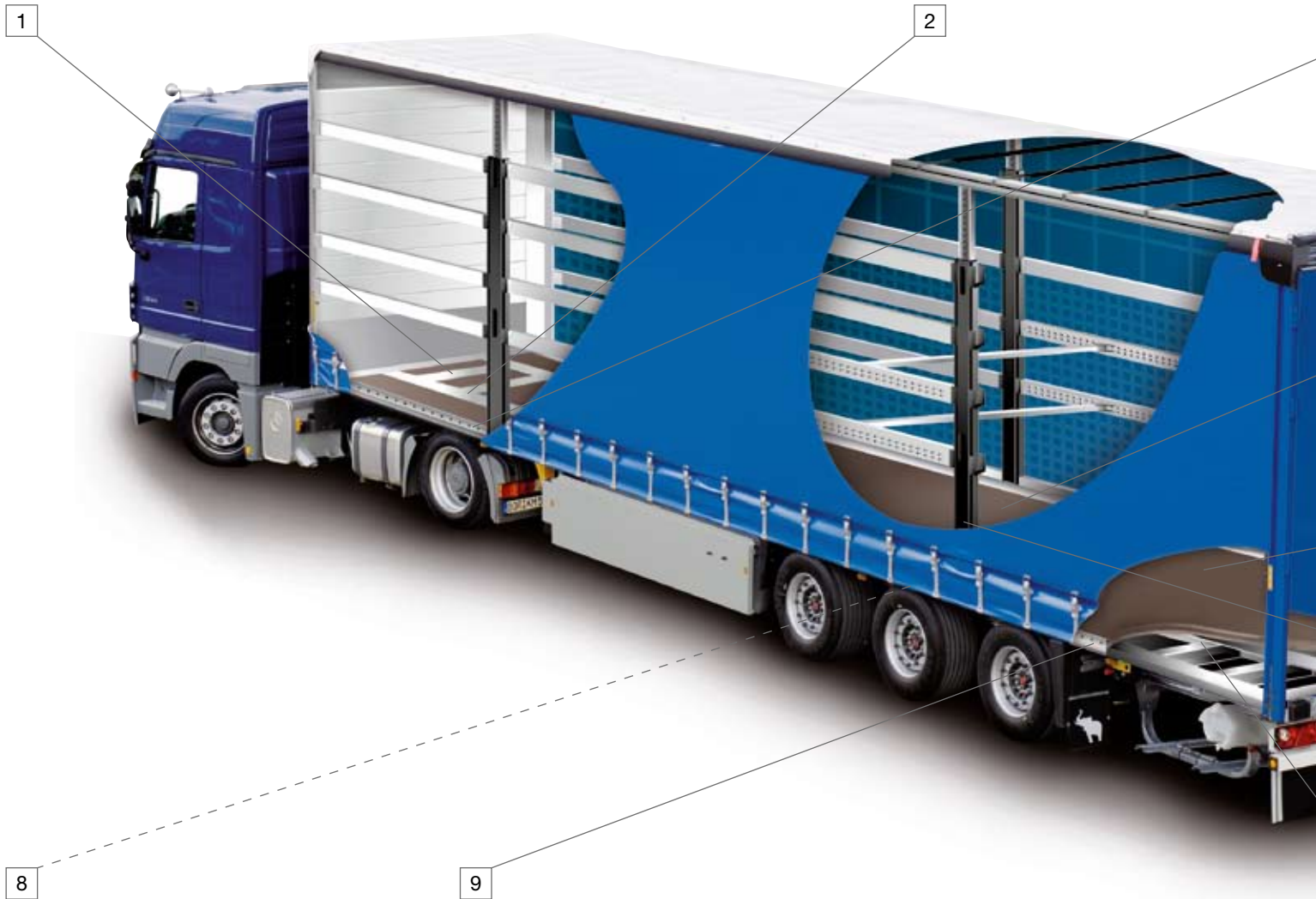

1

2

8

9



8

Bolted gripping strips for the combined traffic, flatbed fittings can be retrofitted



9

Hot galvanised chassis The galvanising of all components already ensures for a high value stability before bolting



3

Through load-securing holes in the outer frame



4

Wear plate at the end of the floor minimises floor damage from abrasive loads



5

Eight pairs of additional stanchions can be inserted in the central/outer stanchion pockets



3

5

6

10

11

7



6

Four pairs of perforated rails fitted in the floor over the whole vehicle length with load securing wedges

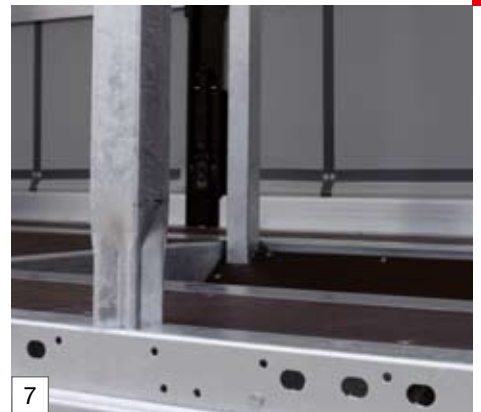

7

Four pairs of coil combi-supports for the body (80 x 80) and outer frame (70 x 70) according to SIDMAR regulation



10

Chassis construction for a forklift axle bearing load of 7.1 t



11

Retrofittable, bolted ferry rings for safe sea transport

BODY

CHASSIS

RUNNING GEAR

ACCESSORIES / OPTIONS



1
Front axle lift with automatic lifting and lowering

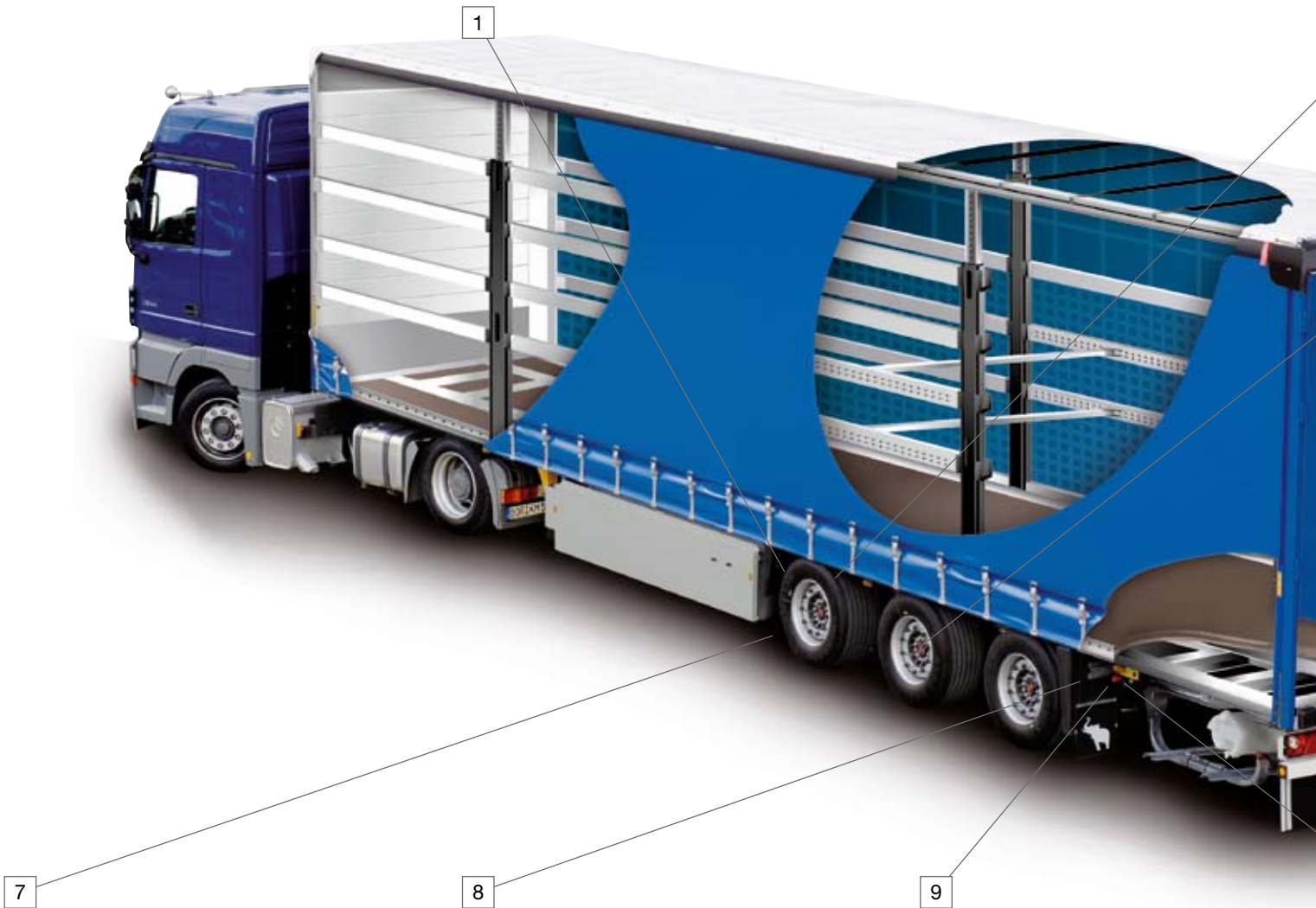

7
Tyre pressure control system, increases the mileage and reduces tyre damage



8
Trailer information system for displaying vehicle data, such as axle load, brake pad wear and mileage





2

Aluminium rims reduce the empty weight and increase the value of your vehicle



3

ROTOS® running gear with 22.5" internally ventilated disc brake



2

3



4

Variable: the MRH air suspension with two driving heights for the different coupling heights

VARIOS
TopTechnology



5



6

Safety in every position – the integrated RSP electronic stability program ensures safe braking in a curve during critical situations



10

Compressed air-operating unit with AUTO-RESET stability program reduces bellow damage

BODY

CHASSIS

RUNNING GEAR

ACCESSORIES / OPTIONS



1
Front release device for quick opening and closing of the side tarpaulins



2
Fire extinguisher fitted on the bulkhead



3
Document tube for vehicle papers and service log

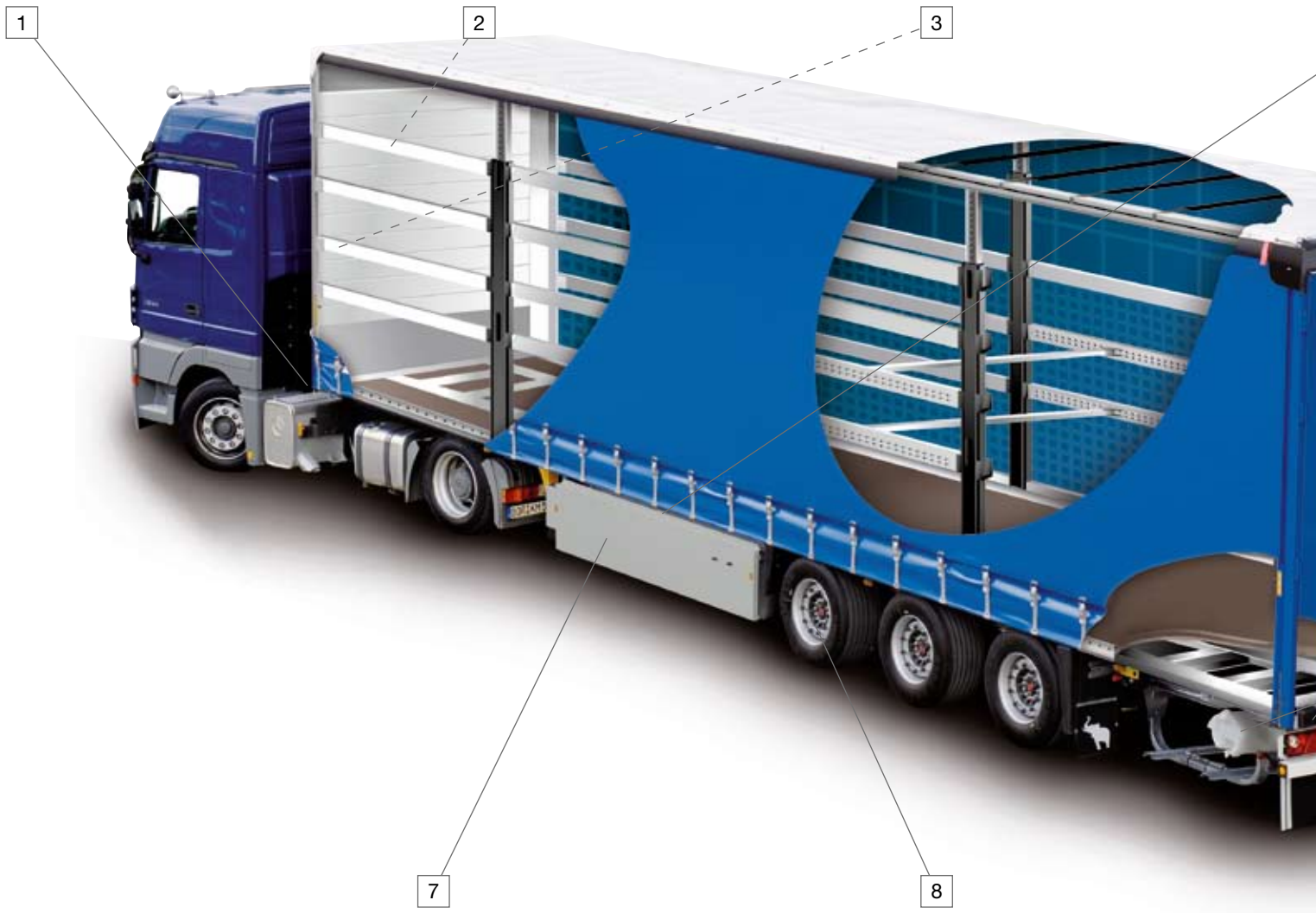

7
Galvanised pallet box for 24 pallets



8
Hub-odometer for mileage monitoring



Brackets for support laths on the side of the I-beam



Screw-out corner stanchions for a through loading width up to 3,350 mm

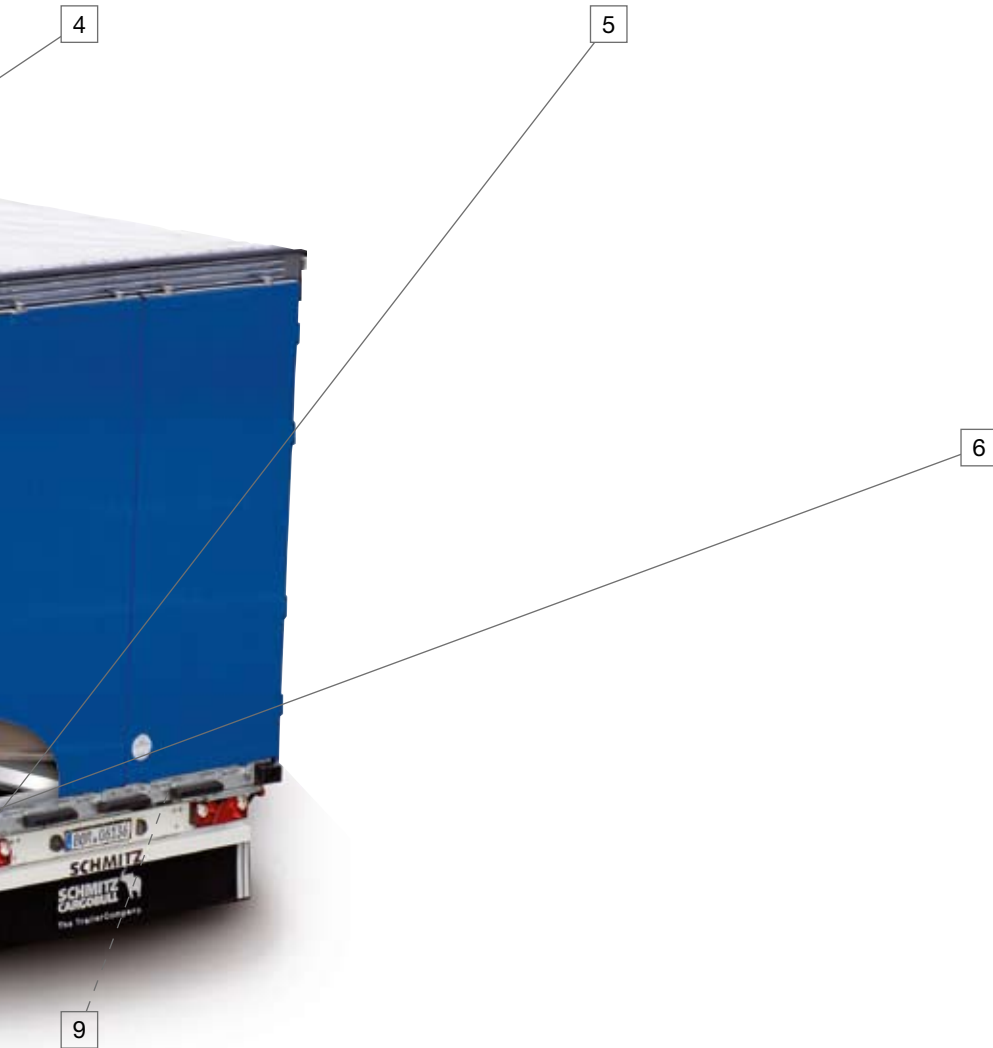

30-litre plastic water tank



Plastic tool box with drawer

BODY

CHASSIS

RUNNING GEAR

ACCESSORIES / OPTIONS



The Trailer Company.

Trailer

Reefer semitrailer



Curtainsider



Tipper trailer



Intermodal Transport



Services

- Consulting
- Financing
- Full Service
- Spare Parts
- Repairs
- Telematics
- Second-hand vehicles
- Service Partner Network