



## Reefer Semitrailer S.KO

### Configurator

*just more.*



## Your semitrailer – configured individually

Using this brochure, you are able to choose the Reefer semitrailer that fulfills your requirements and expectations – from the body to the chassis and running gear up to any accessories. Our modular system makes this possible.

Overleaf you will find a table with all the basic components of a Reefer semitrailer as well as optional special equipment. This can be filled out together with our field service staff. You only have to mark with a cross the additional elements that the trailer should be fitted with for your special purposes. Your details are the basis for making a proposal.

For optimum orientation, we will present you each equipment version using sev-

eral illustrations and descriptions on the inside of the brochure. This enables you to have a better impression of the variety of components available.

Another tip: Leave the table folded out when browsing through. This provides you with a better overview of the equipment, including all options at a glance, and makes the desired compilation of your trailer easier.

The Schmitz Cargobull modular system for more flexibility and investment security – **just more.**

Also, use our range of services for optimising your transport tasks.

● Basic fittings      ○ Optional special fittings (please tick)

1. Temperature recorder with integrated printer	<input type="radio"/>	12. Aluminium grooved plate with floor pan including frame scuff rails	<input checked="" type="radio"/>
2. ATP/FRC test	<input type="radio"/>	Floor load bearing capability 5.5t (see fig. 15) DIN EN 283	<input checked="" type="radio"/>
3. Ventilation flap next to the cooling unit	<input type="radio"/>	Floor load bearing capability 7.1t (see fig. 15) DIN EN 283	<input type="radio"/>
4. Refrigeration unit Carrier <input type="checkbox"/> Thermo King <input type="checkbox"/>	<input type="radio"/>	13. Rear doors made from FERROPLAST®	<input checked="" type="radio"/>
5. Circulation wall including pallet stop	<input type="radio"/>	14. Rear panel frame with roll-up door	<input type="radio"/>
6. Flexible ventilation ducts	<input type="radio"/>	15. Full-height door protection strips	<input type="radio"/>
7. Circulation sections	<input type="radio"/>	16. Load securing rails the side wall	<input type="radio"/>
8. Meat rack	<input type="radio"/>	17. Additional scuff rails	<input type="radio"/>
9. Longitudinally displaceable, insulated transverse partition panel	<input type="radio"/>		
10. Multi-temperature version / roof evaporator	<input type="radio"/>		
11. Double-decker system the side wall	<input type="radio"/>		

1-2. Rail loading capability	<input type="radio"/>
3. Support stand for unaccompanied ferry transport	<input type="radio"/>
4. Galvanised short chassis	<input checked="" type="radio"/>
5. Wheel holder for 2 spare wheels (behind the running gear)	<input checked="" type="radio"/>
6. Ferry fittings / lashings (accompanied / unaccompanied)	<input type="radio"/>
7. Standard tail lift (not illustrated)	<input type="radio"/>
8. Under run tail lift (Schmitz Cargobull version)	<input type="radio"/>
9. Side guard	<input checked="" type="radio"/>
10. Complete anti-spray fittings	<input type="radio"/>
11. Head frame with diagonal cross members at rear	<input checked="" type="radio"/>
12. Bolted underride guard	<input checked="" type="radio"/>

1. MRH pneumatic suspension	<input checked="" type="radio"/>
2. Axle lift, automatic lifting and lowering	<input checked="" type="radio"/>
3. ROTOS® running gear with 22.5" internally ventilated disc brake	<input type="radio"/>
4. EBS with RSP stability program (Roll Stability Program)	<input checked="" type="radio"/>
5. TIS (Trailer Information System) optional with hub-odometer and axle load display, optional with brake pad wear indicator	<input type="radio"/>
6. Running gear operating unit with AUTO-RESET function	<input checked="" type="radio"/>
7. Tyre pressure control system	<input type="radio"/>
8. Steel rim	<input checked="" type="radio"/>
9. Aluminium rim	<input type="radio"/>

1. Cargobull Trailer Telematics	<input type="radio"/>
2. Fire extinguisher mounted in a plastic box	<input type="radio"/>
3. Telescopic cargo bars, both sides fitted with rubber feet	<input type="radio"/>
4. TIR customs seal	<input type="radio"/>
5. 30-litre water tank	<input type="radio"/>
6. Reverse warning display	<input type="radio"/>
7. Document tube	<input type="radio"/>
8. Plastic diesel tank with lockable tank cap	<input type="radio"/>
9. Pallet box for 36 euro-pallets fitted in front of the axle unit, with painted lid	<input type="radio"/>
10. Plastic toolbox with drawer	<input type="radio"/>
11. Compression roller rubber bumper for the effective shock absorption when making contact with the ramp	<input type="radio"/>

BODY

CHASSIS

RUNNING GEAR

ACCESSORIES / OPTIONS



High quality brand cooling units from Carrier or Thermo King



Aluminium wall with defined free space for optimum air circulation at the cooling unit

Body made from FERROPLAST® with metal covering layers: torsion-resistant and lightweight with optimal insulation properties, resistant to external impacts and absolutely vapour-diffusion tight

A pallet stop protects the bulkhead against damage caused by rough loading



Cargobull Telematics (hidden installation) for a transparent logistics chain. Europe-wide detection of the trailer location, obtainable via PC or mobile phone



Galvanized steel pallet box for the trouble-free transport of up to 36 euro-pallets as empties



ROTOS® running gear – improved cooling of the brake system thanks to an innovative ventilation system, minimized accident risk thanks to the RSP fitted as standard



Galvanized chassis: ideal protection against rust and stone impact, repair friendly thanks to bolted connections



Clearly laid out control panel for the Multi-Ride-Height pneumatic suspension enables quick adjustment of the approach height to the ramp

## Tested by the TÜV, appreciated by our customers

- TÜV confirms: FERROPLAST® is ideal for transporting temperature-sensitive goods.
- Vapour diffusion-tight thanks to the combination of metal skin layers and the high-density foam core

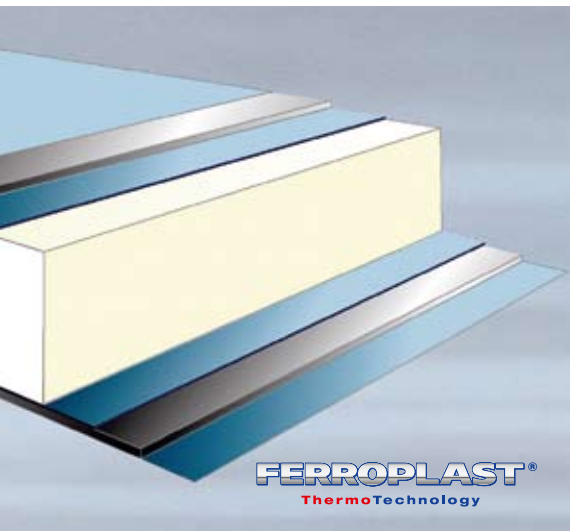

Flexible ventilation ducts for optimal cooling throughout the trailer, also suitable for double deck transport



Easy to use, individually slideable partition wall for the transport of goods at different temperatures



Additional roof evaporator for two temperature controlled temperature zones



The double deck model with individual height adjustment: for the secure transport of up to 33 additional pallets



Flush inlaid rails for quick cargo shift protection



Welded, liquid tight floor pan comprising a lateral kerbing rib and silent easy-glide base for effortless hygienic cleaning

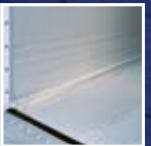

Torsion-resistant hinges in a theft-resistant bonded lock implementation



Bolted and decoupled underride guard for quick and uncomplicated repairs

Acoustic and optical ramp approach aid with ultrasonic scanning for safe docking



## Efficient insulation and transporting with FERROPLAST®

- Outstanding insulating properties through vapour diffusion-tight sandwich panels made of high-density, small pore, CFC-free PU foam core
- Thicker insulation layer compared to GRP walls of the same wall thickness
- Noticeable energy savings: no “thermal bridges”, even in vehicles with twin-temperature zones in the vehicle
- Noticeable cost savings: quick and residue-free cleaning thanks to the rivet- and screw-free flush mounted panel construction
- Can be repaired quickly, easily and economically.
- Self-supporting body and short chassis: weight savings of up to 400 kg less compared to GRP bodies with complete chassis
- Improved protection through shatterproof, burglar-resistant steel sheet casing
- Protected load through the flush mounted load securing rails and the double-deck rails



1



2

Temperature recorder with integrated printer below: ATP/FRC test



3

Ventilation flap next to the cooling unit



4

Refrigeration unit Carrier Thermo King



1-2

3

4

5

12

13

14



12

Aluminium grooved plate with floor pan including frame scuff rails



13

Rear doors made from FERROPLAST®



14

Rear panel frame with roll-up door



5

Circulation wall / pallet stop



6

Flexible ventilation ducts



7

Circulation sections



6

8

10

15

16



8

Meat rack



9

Longitudinally displaceable, insulated transverse partition panel



10

Multi-temperature version / roof evaporator



11

Double-decker system in the side wall



15

Full-height door protection strips



16

Load securing rails in the side wall



17

Additional scuff rails in the side wall

BODY

CHASSIS

RUNNING GEAR

ACCESSORIES / OPTIONS



1



2

Rail loading capability; suitable for multimodal transportation e.g. fitted with folding, rear collision guard, and side gripping pockets. Also available in rail loading versions



1-2

8

9



8

Side guard



9

Complete anti-spray fittings



3

Support stand for unaccompanied ferry transport



4

Galvanised short chassis



5

Wheel holder for 2 spare wheels

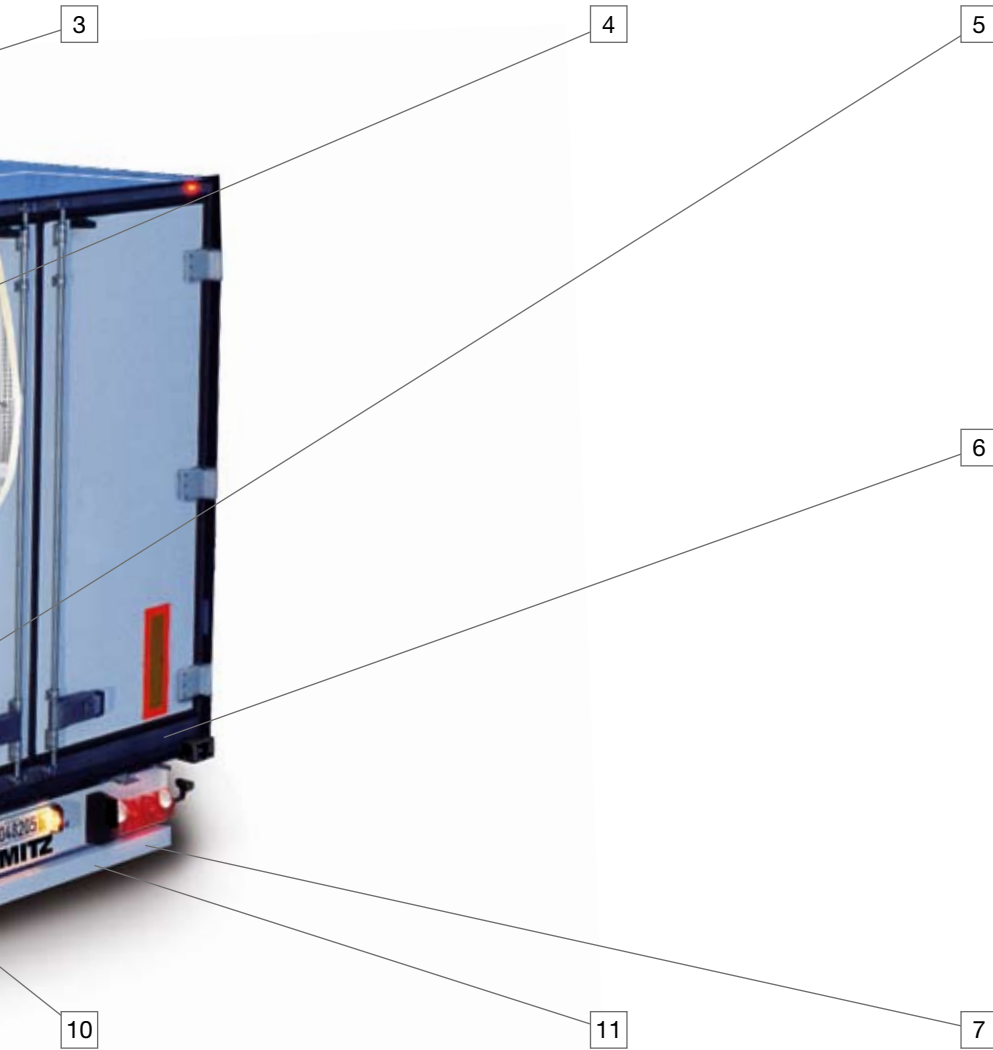

3

4

5

6

10

11

7



6

Ferry fittings / lashings (accompanied / unaccompanied)



7

Under run tail lift (Schmitz Cargobull version)



10

Head frame with diagonal cross members at rear



11

Bolted underride guard

BODY

CHASSIS

RUNNING GEAR

ACCESSORIES / OPTIONS



1

MRH pneumatic suspension



2

Axle lift, automatic lifting and lowering



1

2

7

8

9



7



8



9

Tyre pressure control system, increases the mileage and reduces tyre damage

Steel rim

Aluminium rim



3

ROTOS® running gear with 22.5" internally ventilated disc brake



4

Safety in every position  
The integrated electronic stability program RSP ensures safe braking in a curve during critical situations.



3

5



5

TIS (Trailer Information System) optional with hub-odometer and axle load display, optional with brake pad wear indicator



6

Running gear operating unit with AUTO-RESET function

BODY

CHASSIS

RUNNING GEAR

ACCESSORIES / OPTIONS



1

Cargobull Trailer Telematics



2

Fire extinguisher on the chassis



7

8

9



7

Document tube



8

Plastic diesel tank with lockable tank cap



9

Pallet box for 36 euro-pallets fitted in front of the axle unit



3

Telescopic cargo bars, both sides fitted with rubber feet



4

TIR customs seal



5

30-litre plastic water tank

BODY

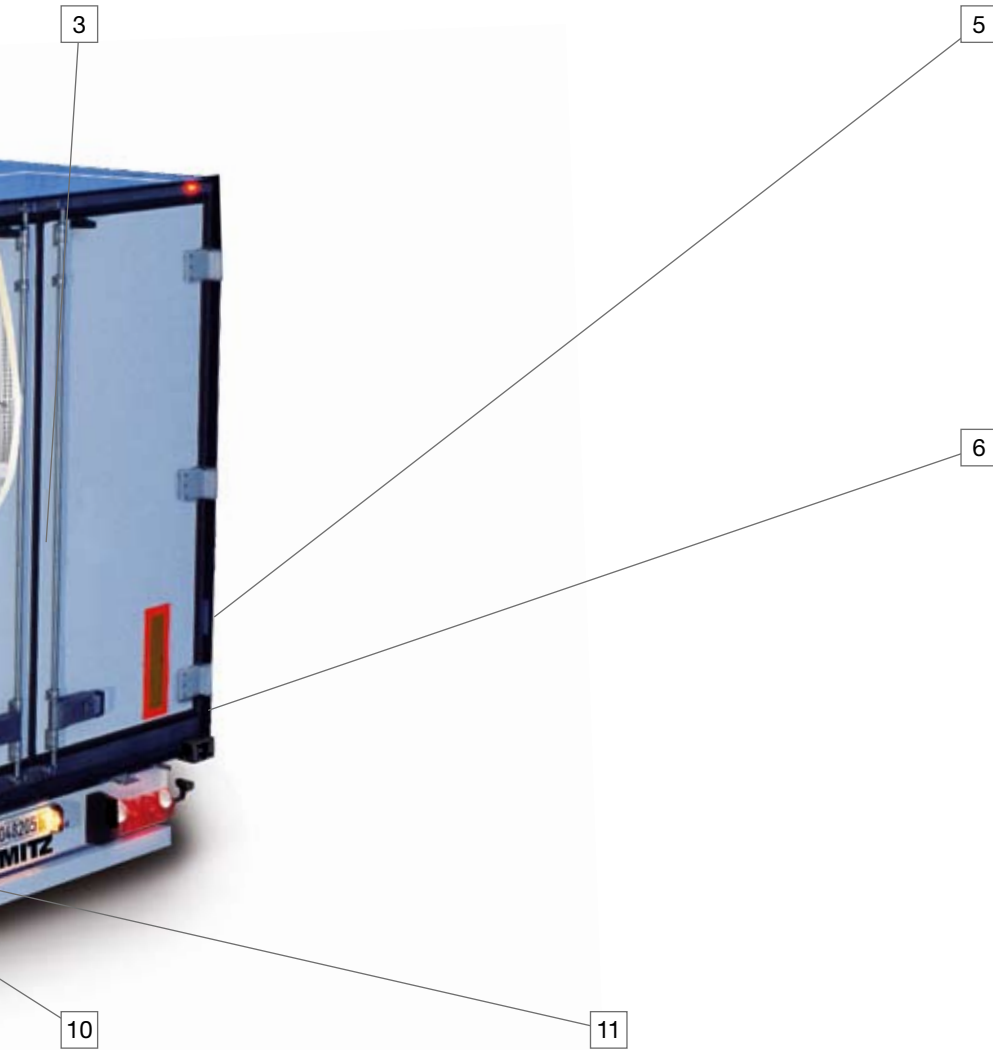

3

5

6

10

11



6

Reverse warning display

CHASSIS



10

Plastic toolbox with drawer



11

Compression roller rubber bumper for the effective shock absorption when making contact with the ramp

RUNNING GEAR

ACCESSORIES / OPTIONS



The Trailer Company.

**Trailer**

Reefer semitrailer



Curtainsider



Tipper trailer



Intermodal Transport



**Services**

- Consulting
- Financing
- Full Service
- Spare Parts
- Repairs
- Telematics
- Second-hand vehicles
- Service Partner Network